

The Forces of Flight

A Lesson Plan for Math and Physics

Bonnie Goonen & Susan Pittman-Shetler



Understanding the Four Forces of Flight

Throughout history, man has longed to fly. We can run, jump, crawl, and even swim, but our bodies are not made to soar with the birds. That did not stop inventors from trying. They created human-sized wings and flapped as hard as they could. Some even jumped from very high places, but human muscles are not strong enough to keep us in the air. Today we still cannot fly as freely as birds, but we can travel in airplanes, helicopters, and hang gliders. It took hundreds of years, and much experimenting before scientists learned that there are four forces that affect flight. Scientists call the study of flight and its forces aerodynamics. Without these forces working together, we would never get off the ground.

Travelers who must go long distances often prefer airplanes, because planes are much faster than cars. However, planes do not move quickly just to keep airline customers happy. A plane must move forward at a very fast rate in order to take off and stay in the air. The high speed of a moving airplane is caused by the first force of flight, thrust. **Thrust** is the force that keeps the plane moving forward. It can be created by a powerful jet engine, airplane propellers, or rocket engine. Drag is the second force of flight. **Drag** is the force that pushes against the plane and slows it down. It may look like planes are flying through empty space, but that space is full of air. Like everything else on Earth, air has weight. Air creates drag, because the plane has to work to push through it. If the drag created by the air is greater than the thrust, the plane will not be able to fly. The third force of flight has a name you may know very well-gravity. **Gravity** is the force that holds everything to the Earth. Gravity is what causes people and things to fall down, toward the Earth, instead of floating up and away. Without it, we would have a hard time keeping our feet on the ground! Gravity also affects airplanes. Like any object, airplanes are held on the surface of the planet by gravity. In order to take off, the plane must overcome this force.

Fighting against gravity takes a lot of thrust. It also requires the fourth force of flight. **Lift** is the force that allows a plane to *lift* off the ground and stay in the air. Lift is created when air passes very quickly over and under the wings of the airplane. Airplane wings are perfectly shaped so that air passes over a wing much faster than it passes under. This creates low air pressure above the wing, and high pressure below the wing. The result is lift.

Summing Up

Airplanes are complex machines. Despite their size and thousands of parts, they only need four forces to get lift off and stay in flight. Thrust moves a plane forward. Drag slows it down. Gravity pulls a plane down toward the Earth, and lift raises it up into the sky. To stay in the air, the plane must have enough thrust to fight against the drag. It must also have enough lift to overcome the Earth's gravity. To slow down and land, the plane will need more drag than thrust, and the lift must be weaker than gravity. Thrust, drag, gravity, and lift all work together to get heavy airplanes- and their passengers- safely around the world.

Understanding the Four Forces of Flight Questions

Read the questions below and circle the letter of the correct answer.

1. How does thrust help a plane fly?

- a. Thrust lifts the plane up.
- b. Thrust gives the plane speed.
- c. Thrust slows the plane down so it can land.
- d. Thrust lifts air beneath the wings.

2. If drag is greater than thrust, what will happen to the plane?

- a. The plane will go faster.
- b. The plane will travel slower and higher.
- c. The plane will go faster and higher.
- d. The plane will go slower and be unable to fly.

3. How do wings help airplanes fly?

- a. The shape of airplane wings helps create lift.
- b. Wings create thrust, which speeds the plane up.
- c. Wings fight drag and keep the plane moving forward.
- d. Wings slow the plane down.

4. If lift is greater than gravity, what will happen to the airplane?

- a. The plane will fly downward.
- b. The plane will fly upward.
- c. The plane's flight will not change.
- d. The plane will not be able to fly.

5. Where does an airplane get its thrust?

- a. wings
- b. tail
- c. wheels
- d. engine or propeller

Draw a line to connect the name of the force to its definition.

Gravity	keeps the plane moving forward
Thrust	pushes against the plane and slows it down
Lift	pulls everything toward the Earth
Drag	raises the airplane and keeps it in the air

Understanding the Four Forces of Flight Answers

Multiple Choice

1. B
2. D
3. A
4. B
5. D

Matching

Gravity	pulls everything toward the Earth
Thrust	keeps the plane moving forward
Lift	raises the airplane and keeps it in the air
Drag	pushes against the plane and slows it down

Short Answer

(Answers will vary. Points can be awarded based on reasoning and accuracy.)

If the flaps (or elevators) are bent up, there will be more drag on the top of the wing. If the drag is greater on top, the plane will be “slower” on top than it is on the bottom, the nose will point up and the plane will travel higher. For older students, this can also be explained in terms of air pressure. Elevators in the up position create lower pressure under the wings and greater pressure on top. The higher air pressure on top pushes down on the rear of the wings and causes the nose of the plane to turn upward.

Directions for Paper Airplanes

Folding Technique - Folding technique is **very** important for successful flights. Make each of the folds carefully and accurately according to the instructions. Creases should be made by applying pressure to the fold with the edge of your thumbnail. This is best achieved by holding your thumbnail on the fold, applying pressure, and pulling your thumb along the fold line toward you. This will produce clean, crisp folds that will allow for accurate paper planes. If you make a mistake on a fold that you cannot correct, don't be discouraged! Just print another template.

Line Types – There are two main types of lines referenced by the instructions: fold lines and cut lines. Fold lines are dashed and cut lines are dotted.

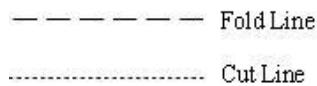

Model Adjustments – No matter what anyone tells you, EVERY paper airplane needs fine-tuning to achieve its best performance. There are several things you should keep in mind while making adjustments to your planes.

Dihedral – Dihedral is a slight upward tilt of the wing tips with respect to the fuselage or body of the airplane. This produces a slight V-shape to the wings when viewed from the front of the plane. Dihedral provides aerodynamic stability to your models by making them want to self-center during flight. Paper airplanes have no intelligent flight controls after they leave your hand, so the plane needs to be naturally stable or else it will crash. All designs on this site perform better when some dihedral is added to the wings.



Front View
With Dihedral, Good



Front View
No Dihedral, Bad

Elevator – Elevator is the aeronautical term for the hinged flap at the tail section of a plane that causes it to either climb (gain altitude) or dive (lose altitude). In paper airplanes these flaps are generally located on the trailing edge of the wings themselves, since there is rarely a separate tail. They are formed by making parallel cuts about 1 inch apart. This produces a small flap that can be folded slightly up or down. Tilting the elevator flaps up will cause the plane to climb. Tilting them down will make the plane want to dive. If you find that your models are heading nose-down toward the ground shortly after launch, you may need to add some up elevator. Likewise, if they are looping-up too quickly or stalling, you may need to add some down elevator. Adding slightly more elevator to one wing than the other will cause the plane to either turn to the right or left.

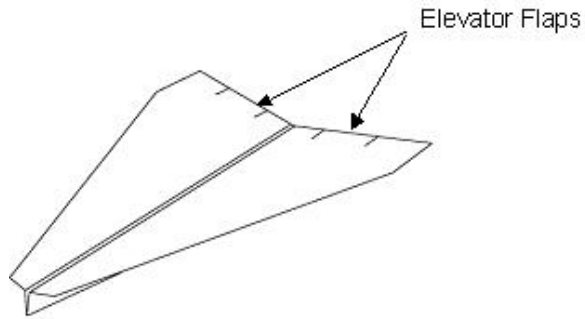

Fun Paper Airplanes. Retrieved from the World Wide Web at:
<http://www.funpaperairplanes.com/Plane%20Downloads.html>

Sample Videos for the Classroom

How Airplanes Fly. Retrieved from the World Wide Web at:
<http://www.youtube.com/watch?v=gk6rNFVc1Gs>

How Do Airplanes Fly? Retrieved from the World Wide Web at:
<http://www.youtube.com/watch?v=bv3m57u6ViE>

History of Transportation: How Do Airplanes Work? Retrieved from the World Wide Web:
<http://videos.howstuffworks.com/hsw/18134-history-of-transportation-how-airplanes-work-video.htm>

Flight Data Sheet

Build your airplane and complete the following flight data sheet.

Team Name:

Team Members:

Trial	Distance
Trial 1	
Trial 2	
Trial 3	
Trial 4	
Trial 5	

Graph your results.

Shortest Trial:

Next:

Next:

Next:

Longest Trial:

Average of the Five Trials:

Design Description:

Notes:



Time Out for Flight Math!

1. If Charles Lindbergh got nine people to sponsor his flight across the Atlantic Ocean and the Spirit of Saint Louis cost \$27,000 how much would each person give to C.L.?
2. If an average small commercial jet airplane carries 73 people that all weigh 125 pounds, and has 1,967 pounds of gas, how much weight is the plane carrying?
3. If an airplane's wing span is 200 feet long, and an eagle's wing span is 7 feet, how many eagle's wing spans equal the wing span of an airplane?
4. If I fly 2000 miles in an airplane a day, how many miles will I fly in a year?
5. To fly around the world the trip would take 12000 miles. If your plane travels at a top speed of 200 MPH how long would it take to fly around the world 5 times?
6. The missile fired 5750 miles down the Pacific to hit an island target. It was traveling at 250 miles a minute. How long did it take to reach its target?
7. There are 17 planes in a hangar on a small field. If 6 planes are missing from each of 2 hangars, and there are 27 hangars, how many planes are there in all?
8. There were 600 planes in an air show. 35 crash and 26 get lost. How many are left?
9. There are 40 kids on the island of Krakatoa and there are 20 husbands and 20 wives and Professor Sherman. There are also three mines of diamonds and in each mine there are 3965 diamonds. If every person on the island is entitled to an equal share of diamonds, how many will each person get?
10. Octave Chanute glided 927 feet, but Olga Klepkova has the record of 465 miles. How much farther did Klepkova go than Chanute? (1 mile = 5,280 feet)
11. Charles A. Lindbergh had 3 tanks in his plane. Each tank was filled with 160 gallons of gas. Amelia Earhart had 2 gas tanks. Each had 200 gallons of gas. How many gallons did everyone have?

Classic Dart

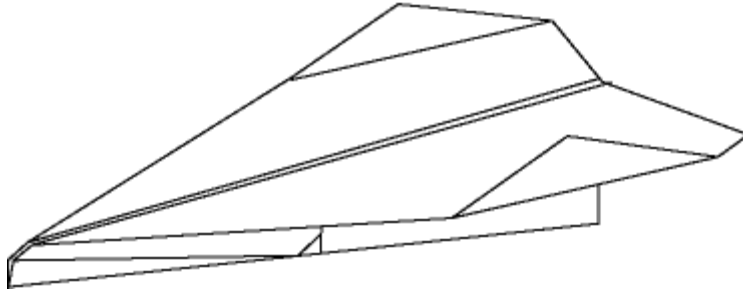

This plane is the classic schoolyard dart. It has short, compact wings and will fly straight as an arrow. It generally needs some up elevator along the back wing edges to fly properly.

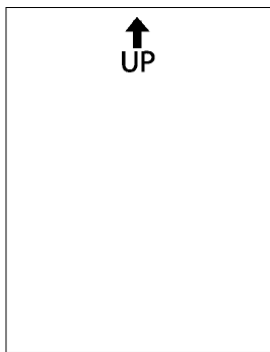

Orient the template with the “UP” arrow at the top of the page. Then, flip the paper over onto its backside, so that you cannot see any of the fold lines.

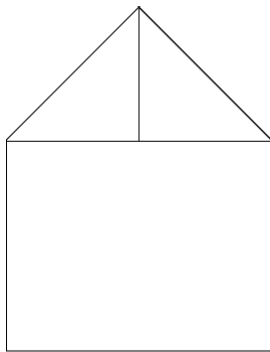

Pull the top right corner down toward you until fold line 1 is visible and crease along the dotted line. Repeat with the top left corner.

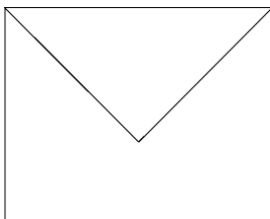

Fold the top point down toward you until fold line 2 is visible and crease along the dotted line.

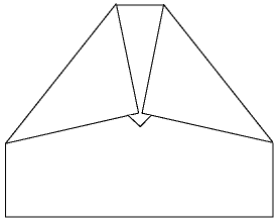

Fold the top left and top right corners down and toward you and crease along fold lines 3.

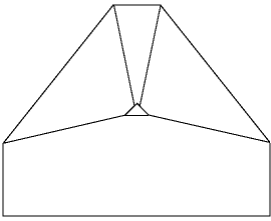

Fold the tip up and over the two diagonal folds along fold line 4 to secure them in place.

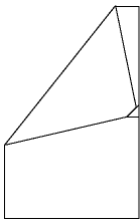

Flip the plane over and fold the right side over onto the left side as shown along fold line 5 so that the outside edges of the wings line up. Also make sure the diagonal folds do not become untucked from the tip you folded up in the previous step.

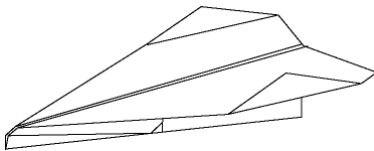

Fold the wings down along fold lines 6 and the winglets up along fold lines 7. Add wing dihedral by tilting the wings up slightly away from the fuselage. The wings will have a slight “V” shape when viewed from the front. Cut two slits, one inch apart, along the back edge of each wing to make elevator adjustments. Start out by trying some up-elevator. You are ready to fly!

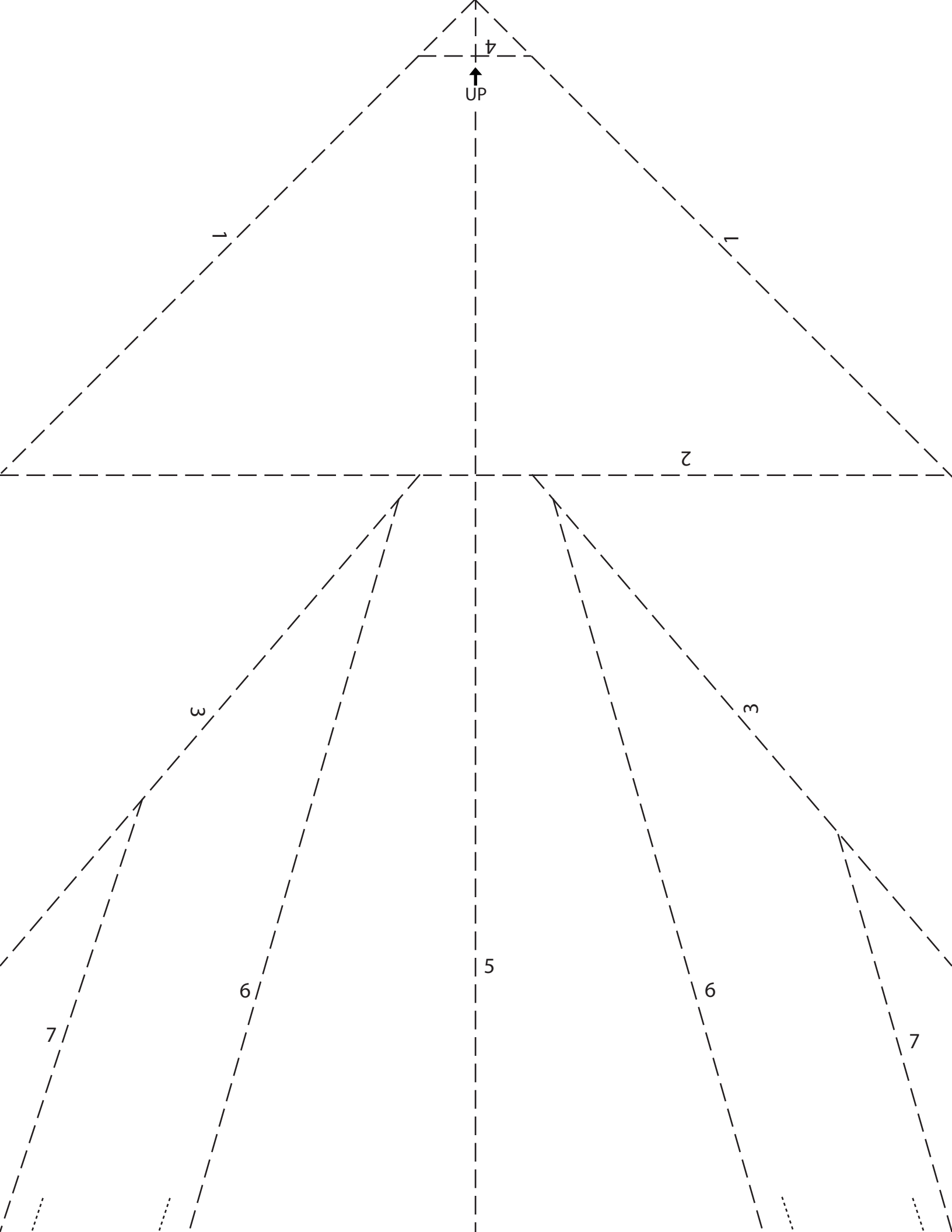

Condor

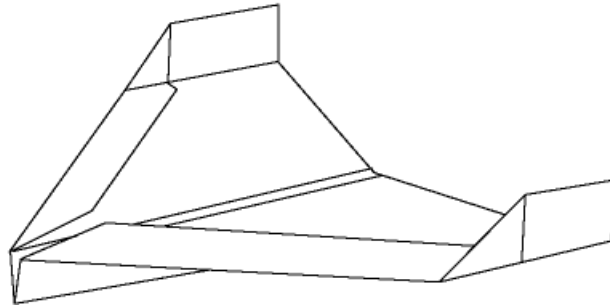

This plane produces tremendous lift at low speed, giving it a very low glide slope. It is an excellent indoor flier and will coast across the room on slow, smooth glides.

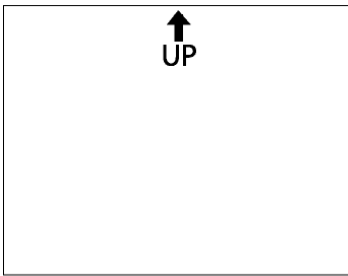

Orient the template so that the “UP” arrow is at the top of the page. Then flip the paper over so that none of the fold lines are showing.

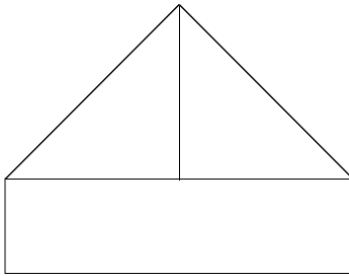

Fold the top left corner down toward you until fold line 1 becomes visible. Crease along the dotted line and repeat with the top right corner.

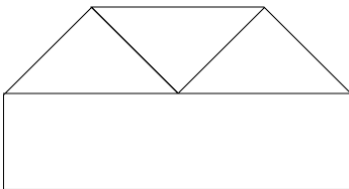

Fold the nose down until fold line 2 becomes visible and crease along the dotted line.

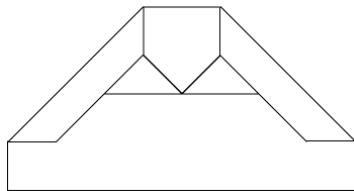

Fold the outside wing edges in and crease along fold lines 3.

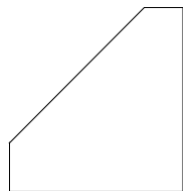

Fold the right half of the plane over the left half and crease along fold line 4 so that the outside edges of the wings line up.

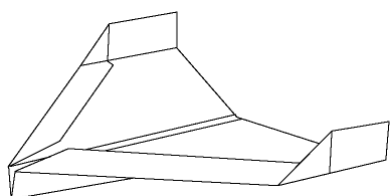

Fold the wings down along fold lines 5 and the winglets up along fold lines 6. Add wing dihedral by tilting the wings up slightly away from the fuselage. The wings will have a slight “V” shape when viewed from the front. Add elevator slits along the back edge of the wings to adjust the flight if necessary. You are ready to fly!

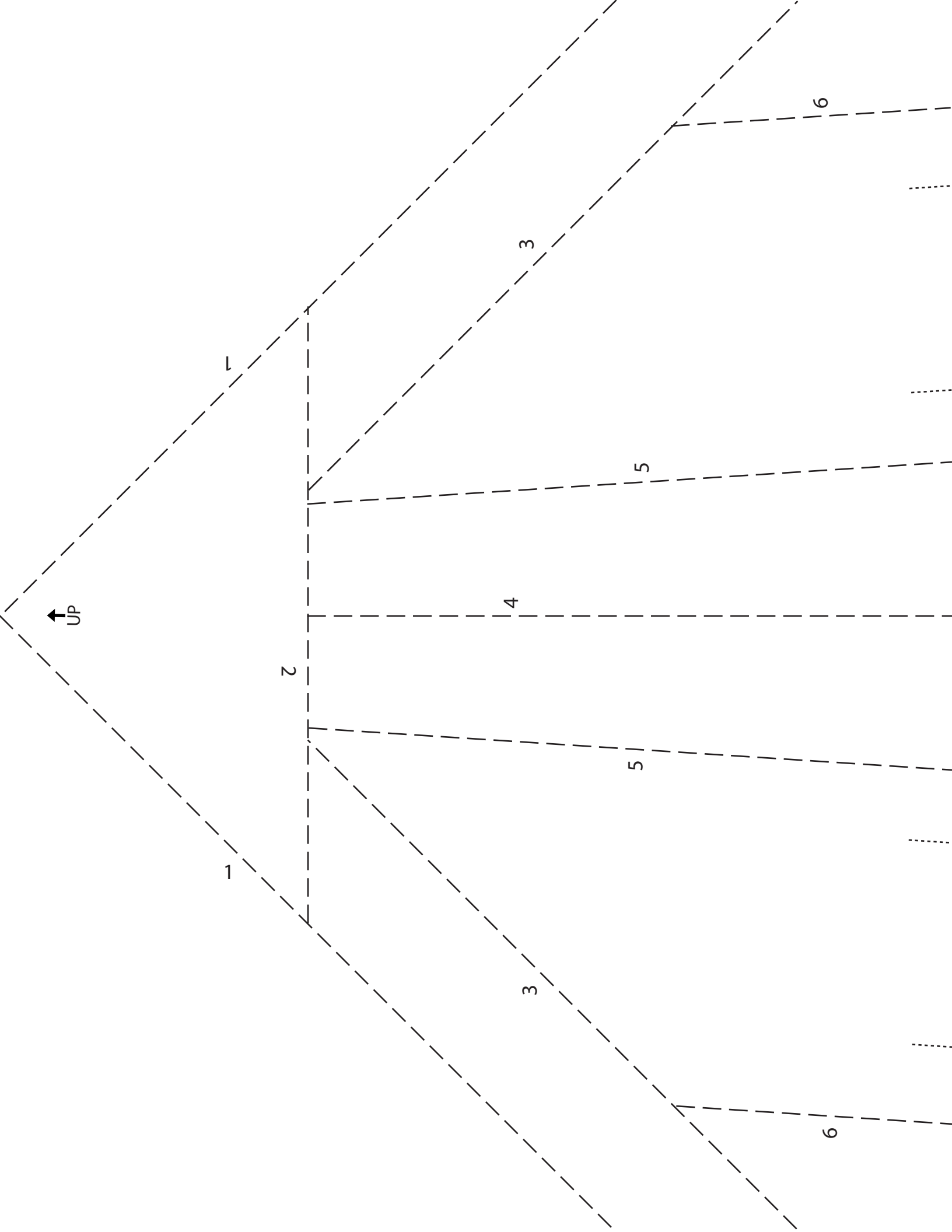

Delta

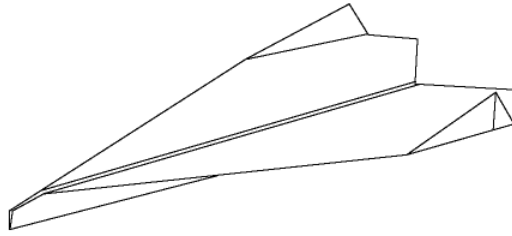

This plane flies fast and straight. It is easy to fold and a great all around flier. Add some up elevator if necessary to produce stable flights.

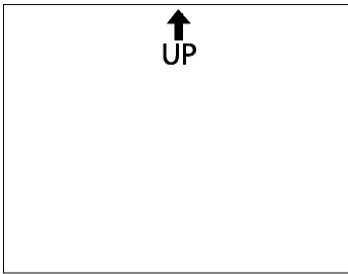

Orient the template so that the “UP” arrow is at the top of the page. Then flip the paper over so that none of the fold lines are showing.

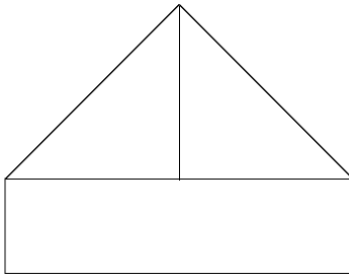

Fold the top left corner down toward you until fold line 1 becomes visible. Crease along the dotted line and repeat with the top right corner.

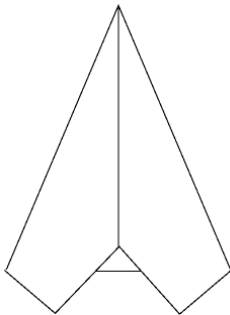

Fold the left side over again and crease along fold line 2. Repeat with the right side.

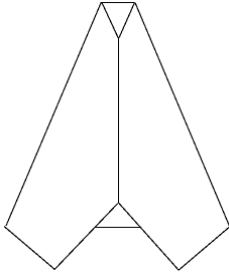

Fold the nose down and toward you along fold line 3.

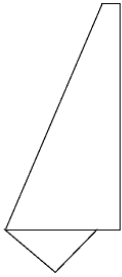

Fold the right half of the plane over the left half along fold line 4 so that the outside edges of the wings line up.

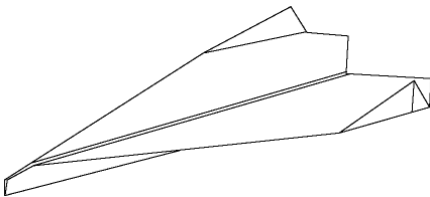

Fold the wings down along fold lines 5 and the winglets up along fold lines 6. Add wing dihedral by tilting the wings up slightly away from the fuselage. The wings will have a slight "V" shape when viewed from the front. You are ready to fly!

